

SP08 SERIES WHEEL SPEED SENSOR



The SP08 Series of Wheel Speed Sensors have been designed as simple compact sensors suited to the demanding motorsport and automotive testing industries.

The main construction is stainless steel which provides for a robust sensor, even in exposed areas such as the engine bay or wheel hub.

By using a proven 'Hall Effect' sensing technology, the SP08 detects a change in magnetic field as the target passes the sensors tip. The output transistor switches its state as the target passes, so giving a measurable pulse train which can be used within standard data logging equipment or ECU's.

TECHNICAL SPECIFICATIONS

Measurement Frequency	1.5KHz
Sensor Type	Hall Effect
Sensing Range (Air Gap)	2 to 3mm
Target Size (Width x Length)	8mm Wide x 1mm Long
Output	NPN or PNP
Max Load Current	100mA
Status Indicator	LED Shows Output On When Illuminated
Supply	10-24Vdc (10mA)
Operating Temperature Range	-40°C to +70°C
Construction	Stainless Steel + PBT
Electrical Connection	100cm 24AWG 55Spec Cable + DR25 Sleeve
Thread Dimensions	M8 x 1 Male 25mm Long, Includes 2x Lock Nuts
Protection Class	IP67
EMC Protection	EN 560947-5-2
Weight (Excluding Cable)	10g
Options	Cable Specifications and Labelling

KA Sensors adopts a continuous development program which sometimes necessitates specification changes without notice.

Sensors For Motorsport

Features

- Miniature Size
- M8 Mounting
- 10-24V Supply
- IP67 Sealed
- Rugged Design

Applications

- Drive Shaft Speed
- Traction Control
- Launch Control
- Wheel Speed

kasensors.com
sales@kasensors.com
+44(0)1476 568057

SP08 10.18

PART NUMBER CONFIGURATOR

Thread Size

Output

Thread Length

Cable Length

Special Code

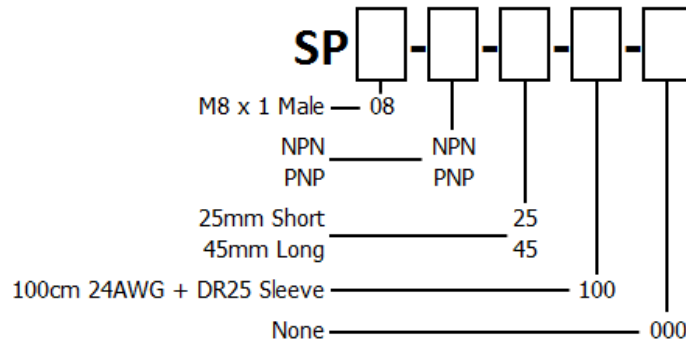

The KA configuration tool is used to specify a standard KA Sensor, other options are available.

MECHANICAL DETAILS

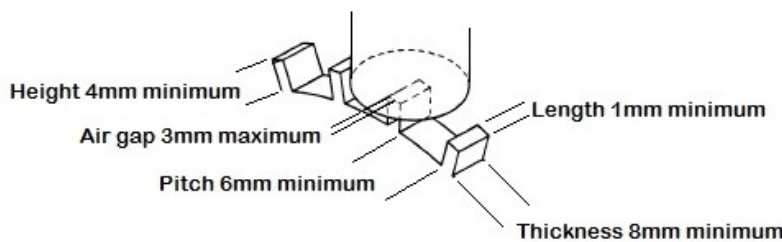
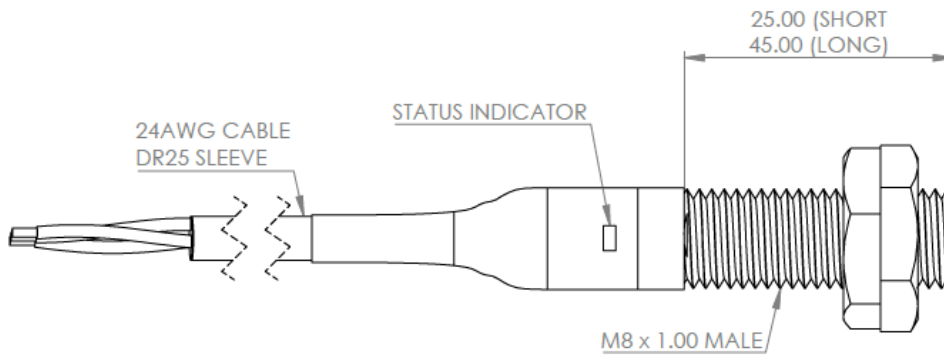

CONNECTION DETAILS

+Ve Supply	0V Supply	Signal
Brown	Blue	Black

*Sense
Analyse
Control*

Services for:

- Data Logging
- Telemetry
- Controls
- Wiring

Contact us

KA Sensors Ltd
Unit 14 & 15
The Old Malthouse
Springfield Road
Grantham
Lincolnshire
United Kingdom
NG31 7BG

kasensors.com
sales@kasensors.com
+44(0)1476 568057

SP08 10.18